

# CG-2040

CITY CRANE

---



## CG-2040 / city crane



The CG-2040 is a compact and powerful mobile crane suitable for different working conditions. The innovative fully adjustable horizontal suspension system, the result of 40 years of experience in the lifting field, allows the most impassable workplaces to be reached. The small dimensions make the CG-2040 the ideal vehicle for lifting and handling operations even in city contexts. The attention to the environment and the low level of emissions allow the free movement of the crane.

# CG-2040 / city crane

TECHNICAL FEATURES	Maximum load capacity	40	T
	Capacity	40	T
	Maximum lifting height	32	m
OPERATING SPEED	Winch speed	67/154	m/min
	Winch rope length and diameter	L 160 Ø 13	mm
	Boom lifting speed	55	s
	Boom extension speed	60	s
	Turret rotation speed	3	r/min
	Maximum speed	65	km/h
CRANE	Maximum slope	30	%
	Road steering radius	11.5	m
	Construction site steering radius	6.5	m
	Emissions	EU 2016/1628	
MASS	Total weight	24	T
	Weight on the 1st axle	12	T
	Weight on the 2nd axle	12	T
DIMENSIONS	Total size	8,600x2,550x3,200	mm
	Boom length	30.65	m
	Boom tilt	-2 +80	°

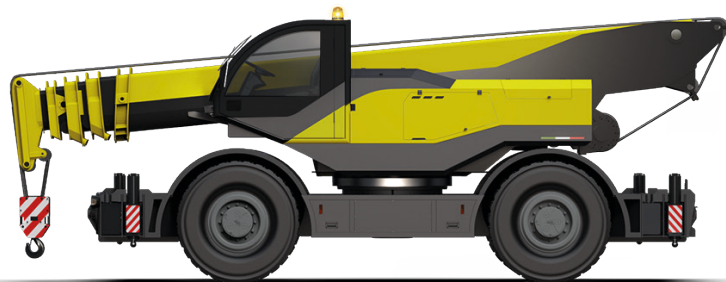

# CG-2040 / city crane

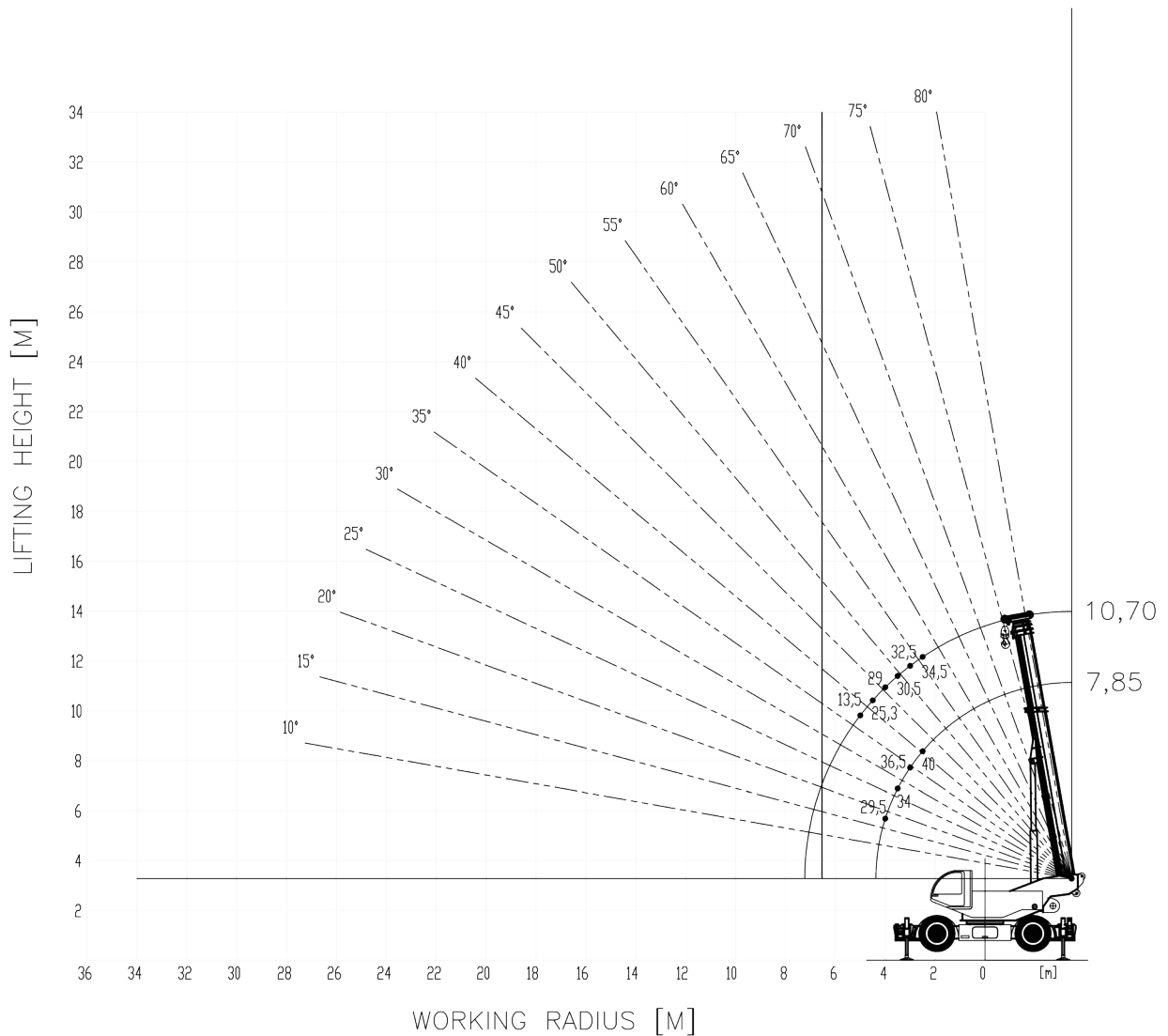

**POWERFUL.** The 6.7 engine of 231 Kw, the permanent all-wheel drive and the gear guarantee the reaching of apparently inaccessible workplaces.

**COMPACT.** The 8.6 m length, the steering radius and the Pick & Carry mode on tires allow lifting and handling both in city and industrial areas.

**FAST.** The easy and ergonomic controls and the wide visibility of the cab reduce machine stabilization operations to a minimum. The independent selection of the 1st extension from the 2nd-3rd-4th offers the operator different lifting configurations.

# CG-2040 / city crane

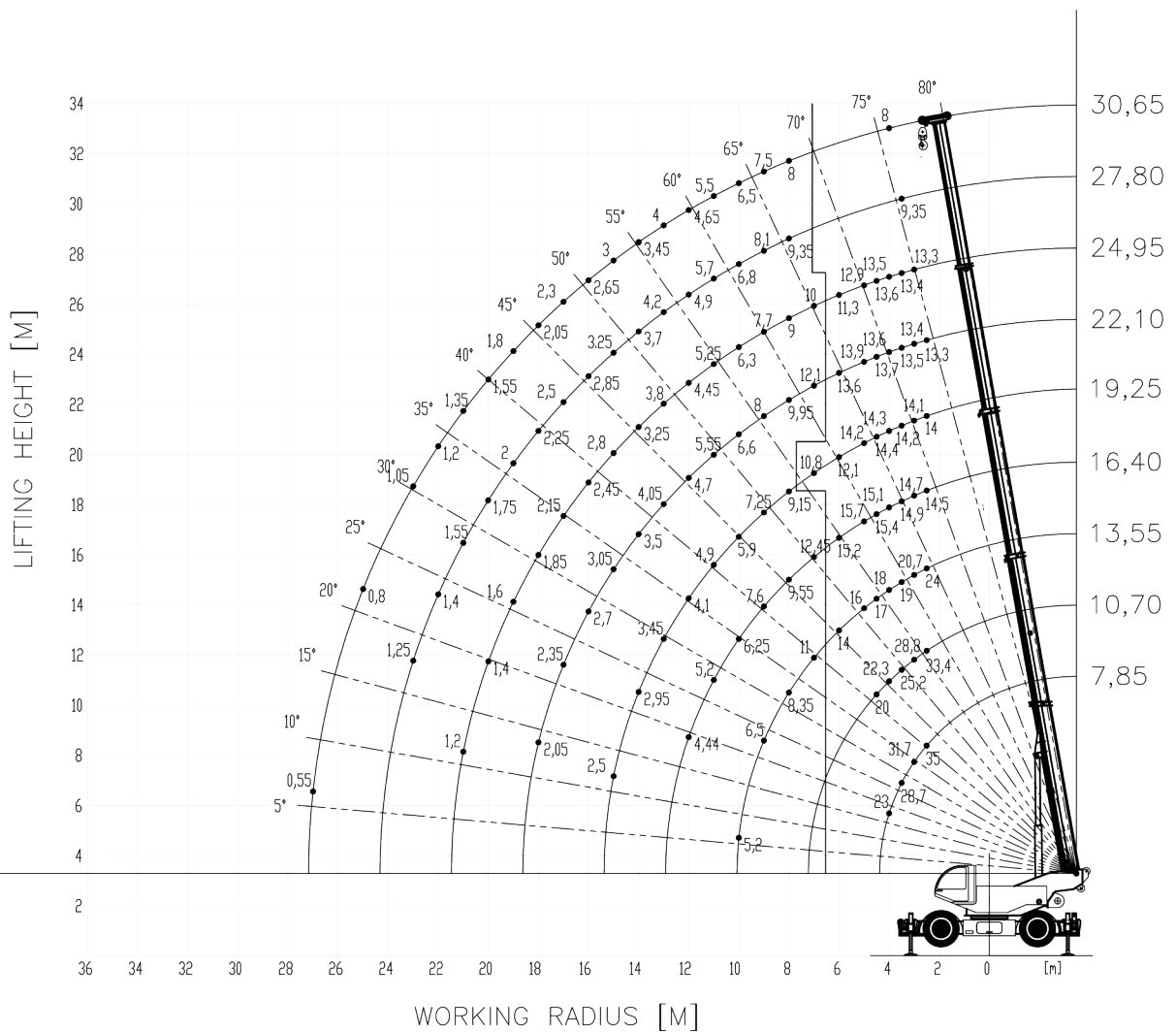

# CG-2040 / city crane

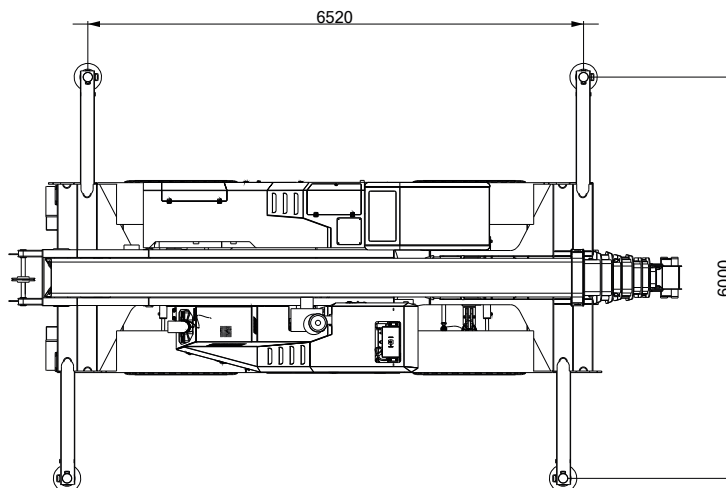
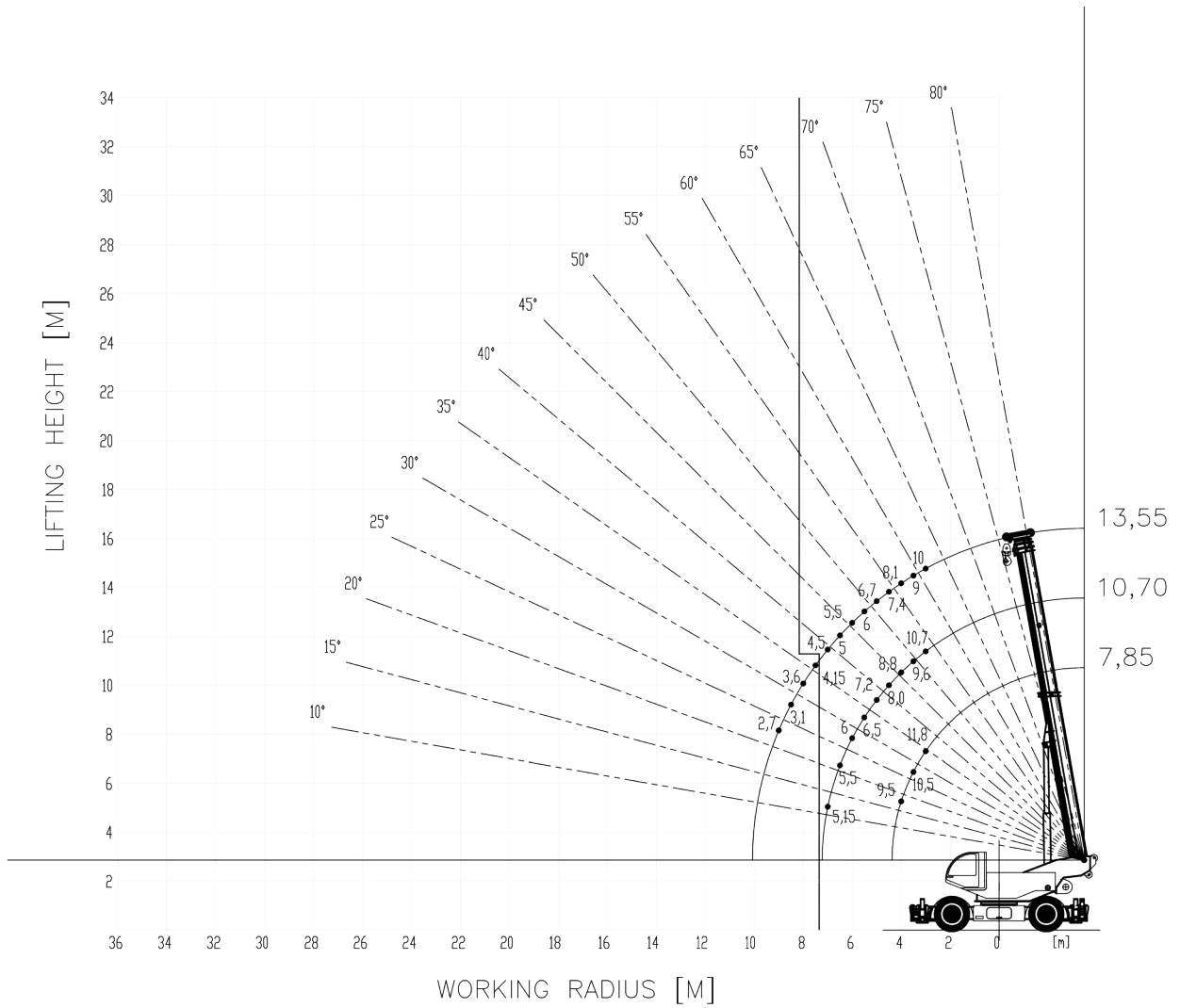

# CG-2040 / city crane

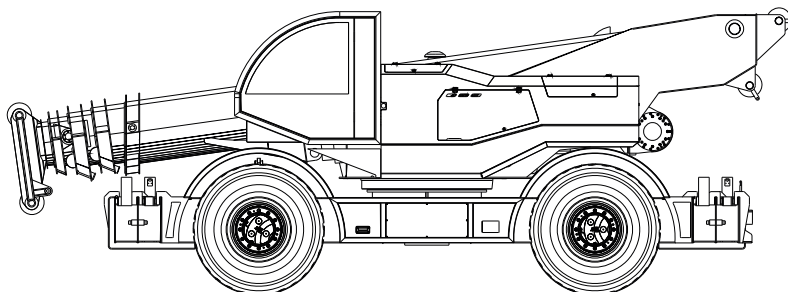
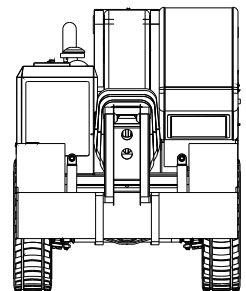
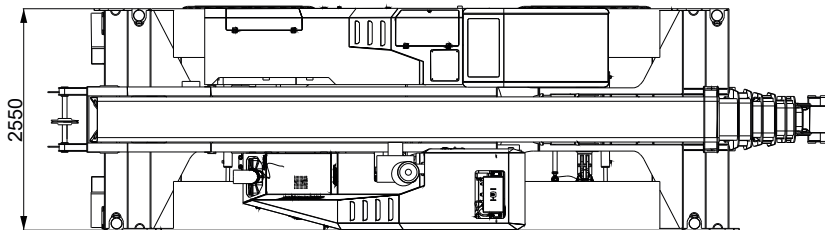
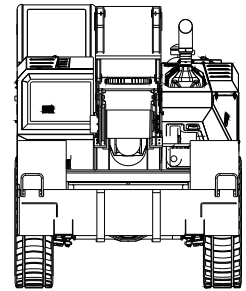
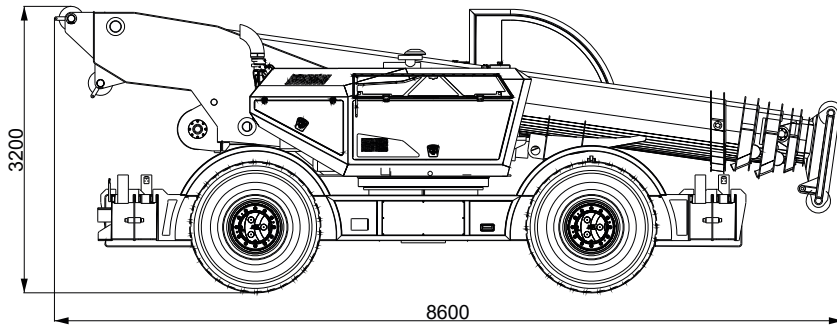

# CG-2040 / city crane

## Equipment

Chassis	
Chassis	Anti-torsion box structure in high-strength steel.
Translation	Hydraulic drive of the translation with TCM electronic control. A pump and two closed-circuit motors allow it to reach 65 km/h. Permanent all-wheel drive 4x4.
Electrical system	CAN Bus data transmission, 24 V.
Gear shift	Two types of selectable translation.
Suspensions	Innovative fully adjustable horizontal suspension system makes driving comfortable and stable. Suspensions with automatic leveling. Height adjustable according to ground conditions $\Delta$ 240mm.
Tyres	385/95 R25
Steering	Power assisted: Bosch hydraulic steering pump. 4 steering modes: road steering, all-wheel steering, crab steering, independent rear steering. 4 steering cylinders. 2 independent hydraulic circuits.
Brakes	Quick activation of the braking system. 8 pneumatically operated brake chambers ensure smooth and safe braking. ABS braking assistance system.

Engine	
Engine	Cummins B 6.7 Stage V- Tier 4f- 231 kW@2200rpm engine.
Diesel tank	300 l
Def tank	38 l
Batteries	2 x 143 Ah

Driving	
Driving	Comfortable driving with height-adjustable and tilt-adjustable steering wheel. Control instruments with ergonomic and functional layout. Rear camera for safely carrying out maneuvers in confined spaces.
Driver's cab	Cabin with great visibility, comfortable and equipped with sliding windows. Front and top safety glass with wiper. Seat with integrated headrest. Wide field of vision for different working conditions. Corrosion resistant paint.
Comfort	Air conditioning, heating and air suspension seat. Seat belts. Ample lighting of driver's cab. Car radio.

Turret	
Chassis	Anti-torsion welded structure, in high-strength steel.
Rotation	Continuous 360° using axial piston hydraulic motor. Planetary gearbox with internal toothed fifth wheel and double row of balls. Multiple disc negative brake.
Control	Hydraulically operated manipulators with the possibility of simultaneous proportional maneuvers.
Lifting winch	Variable displacement axial piston engine. Lifting drum with integrated planetary gearbox and parking brake with multiple discs. Block valve and descent control. Cable gland to improve the winding of the rope on the drum.
Hydraulic system	Open circuit system with axial piston hydraulic pumps. Proportional hydraulic distributors with load sensing power regulation. Possibility of performing multiple maneuvers simultaneously. Heat exchanger for oil cooling. Oil filtering through 1 cartridge filter on the return circuit.
Hydraulic oil tank	400 l
Electrical system	24 V power supply. CAN Bus vehicle management network.
Safety devices	Electronic load limiter with indication of boom inclination, boom length, lifted load, maximum liftable load. Limit switches. Safety valves on all hydraulic functions.
Cameras	1 camera located on the rear side to increase visibility during more restricted maneuvers. 1 camera for supervising the winding of the rope on the winch.
Telescopic boom	Telescopic in high resistance steel. 1 base element, 1 independent extension and 3 synchronized extensions.
Boom extension cylinder	Single two-stage cylinder.
Boom length	30.65 m
Pick & Carry	Lifting up to 11.8 T



PREDISPOSITION FOR OPTIONAL EXTRAS PROVIDED ON DEMAND



# CG-2040 / city crane



All data, technical characteristics and information reported in this document are for informational purposes and are subject to change without any prior notice requirement. All specifications described do not constitute a guarantee since the performance of the machine varies depending on use.

Machine illustrations may contain optional and additional equipment. The dimensional data refers to average reference measurements indicated for informational purposes only.

The commissioning of the machine and its correct use require compliance with the use and maintenance manual.

The weights of hooks, blocks and all lifting accessories are part of the load and must be deducted from the loads indicated.

Please contact TeknoGRC for more information regarding optional and additional equipment.



---

TEKNO GRC srl

via Vecchia Fornace, 31  
24050 Bariano (BG) - ITALY

0363 958311  
[info@teknogrc.it](mailto:info@teknogrc.it)  
[www.teknogrc.it](http://www.teknogrc.it)